

UNIVERSAL MOUNTING (DU-V)

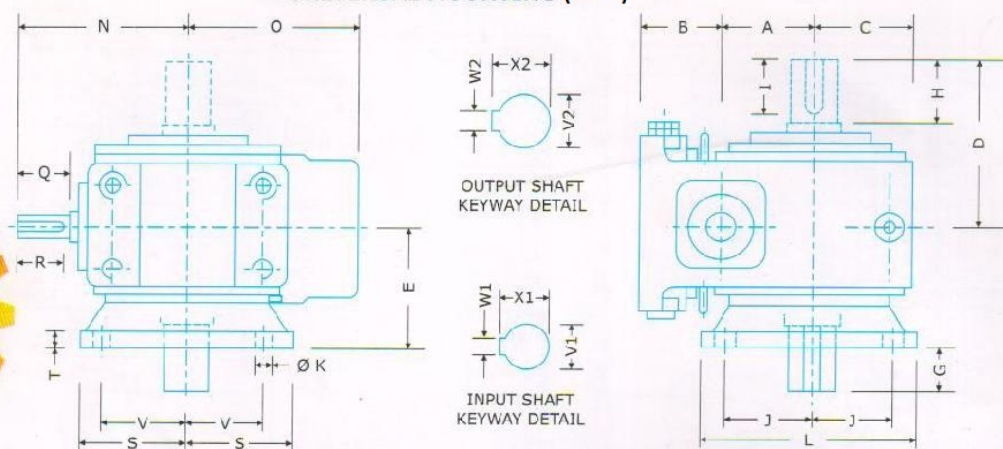

SIZE	OVERALL DETAILS								FIXING DETAILS						SHAFT DETAILS										
	A	B	C	D	E	G	N	O	J	K	L	V	S	T	Q	R	X1	W1	V1	H	I	X2	W2	V2	
4.0	101.6	108	140	215	147.5	67.5	208.5	217	117.5	17	280	117.5	140	23	60	58	40	10	35	90	85	50	10		
5.0	127	118	160	247	166	81	239	255	132.5	19	320	132.5	160	26	60	58	40	10	35	100	95	57	14	50	
6.0	152.4	127	175	253	159	94	230.5	280.5	135	21	350	135	175	24	75	72	43	10	38	110	104	66	16	58	
7.0	177.8	146	200.2	287	200	87	311	345	160	27	400	160	200	40	82	79	43.5	12	40	130	127	69.5	18	65	
8.0	203.2	146	224.8	312	220	92	342	368	180	27	440	180	220	40	86	85	49	14	45	140	137	75	20	70	

FOOT MOUNTED UNDER DRIVEN (FMU)

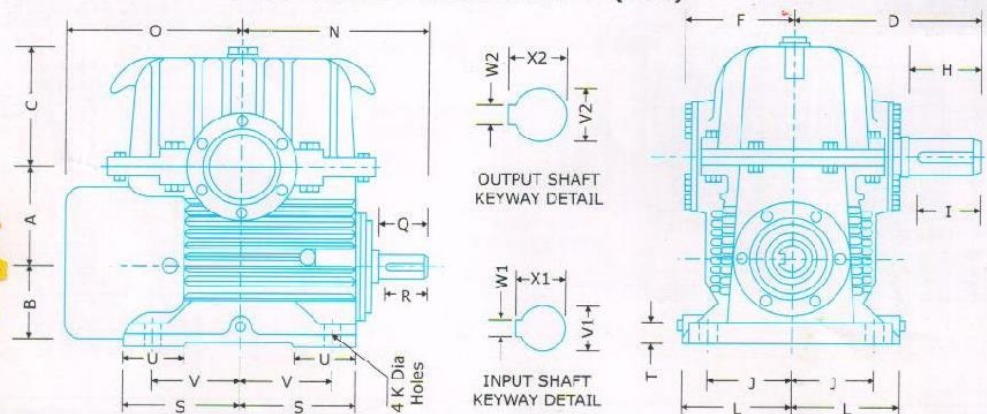

SIZE	OVERALL DETAILS								FIXING DETAILS						SHAFT DETAILS										
	A	B	C	D	F	N	O	J	K	L	V	S	U	T	Q	R	X1	W1	V1	H	I	X2	W2	V2	
7.0	177.8	146	210	293	152	318	292	133	27	162	152	206	95	25	80	78	51	12	45	120	110	69.5	18	65	
8.0	203.2	146	248	316	136	342	392	135	31	172	170	225	101	41	85	80	51	12	45	130	120	75	20	70	
9.0	228.6	159	264	343	194	387	372	155	27	187	215	254	108	28	95	90	54	14	50	131	125	80	20	75	
10.0	254	172	295	375	214	425	381	180	33	210	216	267	117	30	115	100	59.5	16	55	183	170	91	22	85	
12.0	304.8	197	352	481	235	495	457	185	33	220	280	360	127	33	115	110	64.5	18	60	170	165	100.5	25	95	